

GROUNDBREAKING PERFORMANCE FROM THE GROUND UP.

NEW 27 HP 2 CYLINDER LIQUID-COOLED ENGINE

VANGUARDTM
Premium Commercial Engines





INTRODUCING THE **NEW** 27 HP LIQUID-COOLED
VANGUARD™ 2/LC ENGINE





**A COOLER, SMOOTHER, LONGER
RUNNING COMMERCIAL ENGINE.**

**THAT'S THE LIQUID-COOLED
ADVANTAGE OF THE VANGUARD™ 2/LC.**

Built from the ground up, this new, innovative design from Briggs & Stratton includes advanced liquid-cooled engineering to give you the best 27 horsepower engine offering on the planet. The Vanguard™ 2/LC. The newest member of the renowned Vanguard™ commercial engine family represents a total rethinking of what it takes to get the job done. The Vanguard™ 2/LC runs cooler than air-cooled engines. It delivers smoother, quieter performance over the long haul and is CARB/ EPA certified. Designed with you in mind, the core engine will easily accommodate higher horsepower ratings. So you won't be locked into one design size. Upgrade equipment performance and reliability with the Briggs & Stratton Vanguard™ 2/LC. The engine built for the needs of the workplace.



1

INNOVATIVE DESIGN DELIVERS SUPERIOR PERFORMANCE.

By using OHV technology and a compact design that holds 27hp, this innovative 2-cylinder engine produces a whole new level of industrial grade performance.

- Compact 752 cc (46 cubic inch) displacement.
- Increased horsepower-to-weight ratio for more efficient operation.
- V-Twin technology offers superior balance and low vibration, which saves wear and tear on components and equipment.
- Innovative intake and exhaust system results in a quieter running engine.

2

DURABILITY YOU EXPECT.

The innovative design of the Vanguard™ 2/LC delivers over 40% more hours than air-cooled engines. We've specifically engineered key engine components for long life and rugged durability.

- A full 360-degree cooling water jacket reduces engine and oil temperatures to extend engine life.
- Briggs & Stratton full pressure oil lubrication system with spin-on filter keeps the oil cleaner for a longer engine life.
- Compatibility with lifetime coolants makes the 2/LC more reliable with less maintenance.
- 4-inch centrifugal industrial grade air cleaner ensures maximum engine protection, even in dusty conditions.



3

IMPROVED RELIABILITY EQUALS MORE TIME ON THE JOB.

The Vanguard™ 2/LC is designed for easy, dependable starting and convenient maintenance.

- Commercial grade solenoid shift starter means quick, reliable starts.
- Longer service intervals due to liquid-cooled technology.
- Easy access to service points.
- Backed by a two-year commercial warranty.

4

A PREMIUM ENGINE FOR PREMIUM EQUIPMENT.

The Vanguard™ 2/LC is a premium engine that will deliver the performance and durability you expect. Its innovative design and liquid-cooled technology make it run smoother, cleaner and longer. All in a compact, lightweight 27 hp package. It's the engine built to give you groundbreaking performance from the ground up.

To learn more about the Vanguard™ 2/LC and the rest of the Vanguard™ line of commercial engines, connect with our world-class parts and service network, or get assistance from our experts on engine applications, please visit us at www.vanguardengines.com.



PART OF THE VANGUARD™ LINE OF COMMERCIAL ENGINES



**CENTRIFUGAL TWO-STAGE
INDUSTRIAL AIR CLEANER**
for maximum engine protection

**AUTOMOTIVE FAN BELT
TENSIONING DESIGN**

PULSE TYPE FUEL PUMP

**OVERHEAT SENSOR IN
INTAKE MANIFOLD**
is standard

**FULL 360-DEGREE
COOLING JACKET**
reduces engine and oil
temperatures, extending
engine life

**500 LB. THRUST
LOAD CAPACITY**

**HIGH INERTIA
FLYWHEEL**

**EIGHT PIN
WIRE HARNESS
CUSTOMER
CONNECTION**

**FULL PRESSURE OIL
LUBRICATION SYSTEM
WITH SPIN-ON FILTER**
keeps oil cleaner to extend
engine life

**INDUSTRIAL GRADE
SOLENOID SHIFT
STARTER MOTOR**

**LIGHTWEIGHT
ALUMINUM BLOCK**
reduces compaction
and eases handling

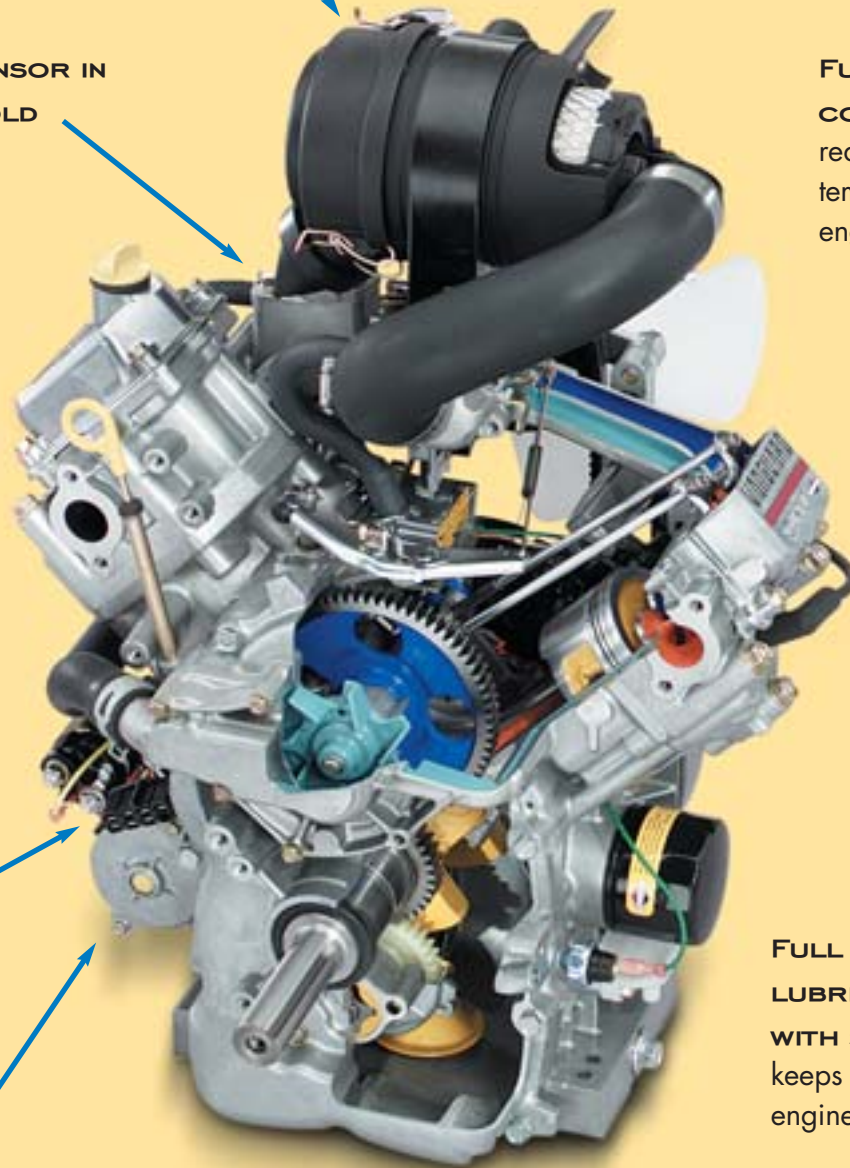

VANGUARD™ 2/LC

27 HP GAS ENGINE

MODEL	27HP 752cc 473147-0112-E1
Cylinder	Twin w/C. I. sleeve
Flywheel	Heavy
Starter	12V solenoid shift 20 amp alternator 8 pin connecting harness
PTO mounting	Flange mount
Special features	Liquid-cooled w/ fan Coolant temp switch Inst. coolant pump install
Radiator	Radiator installed
Bore x stroke [mm (in)]	81 (3.19) x 73 (2.87)
Crankshaft	808942-1-1/8" Straight 4, 1/4" 7/16-20 UNF
Bearings	Steel backed alum mag Steel backed alum PTO
Engine oil capacity	2.6 qt.
Oil fill	In valve cover #1
Dipstick	Extended, in crankcase
Oil drain	Dual Funnel oil filter side
Lubricating system	Oil press switch install Oil filter install Full press lube
Fuel system	Without fuel tank Integral fuel pump 60 micr ftt 6.0 inch line
Governor	Mechanical
Controls	Equip for remote
Choke	Remote choke
No-load test speed	3600 ± 100 rpm
Casing clamp and screw	Loose
Stops	Ground wire terminal lead
Air cleaner	Two-stage centrifugal
Muffler	High mount installed
Deflector	Without
Dry weight w/ muffler, radiator	144.6 lb.
Minimum order qty.	8
Packaging	1

HORSEPOWER/TORQUE

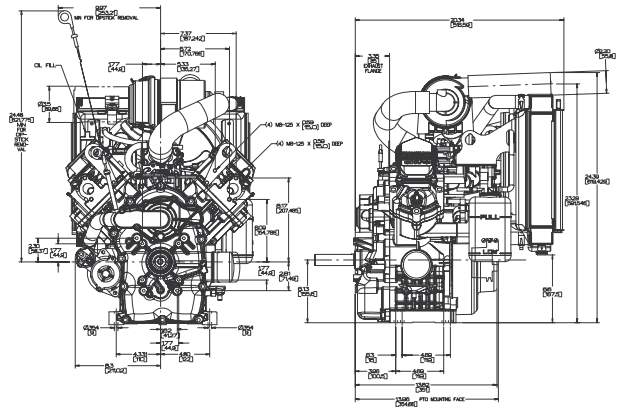
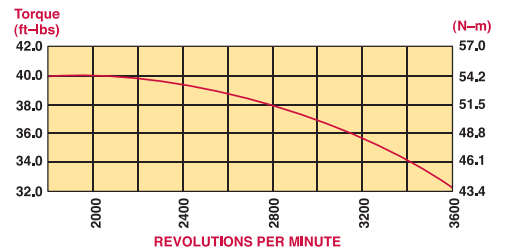
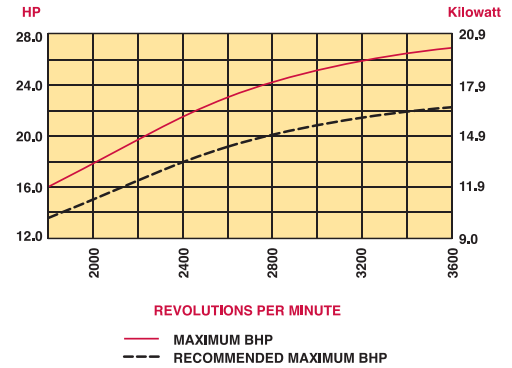

Briggs & Stratton Corporation – Corporate Office
 12301 West Wirth Street Wauwatosa, Wisconsin 53222-2110 U.S.A.
 Tel: 414.259.5333
www.vanguardengines.com

